

16  
Solid-State



# FREE Wheel

ENHANCED 16  
Solid-state system

user guide &  
fitting instructions

*"So eager to order this! Need to ditch my steering wheel umbilical as soon as possible!"*

*"Installation was really straight forward ... and the configuration software worked well"*

*"All installed and tested, works perfectly, insanely pleased :D"*



*"BlinkSTOP.. have done it again!"*

*"my favourite upgrade yet.. get one."*

*"Absolutely amazing.. I'll be sure to recommend your product as it really is a fantastic piece of kit"*

*Thank you for purchasing FREEWheel!*

**FREEWheel, the most advanced wireless steering wheel system in the world.**

Here's all the information you'll need.



### CONTENTS

Solid-state & CAN Receiver and Transmitter  
Battery (3V CR2 or CR123A lithium) & USB cable  
Optionally: two 0.7m looms or connectors & pins  
Optionally: Easyfit Transmitter assembly or switch plate bundle comprising IP67-rated OFF/[ON] momentary switches, nut covers, button plate, spacer disk, decals

### YOU WILL NEED

IP67-rated OFF/[ON] momentary switches  
USB configuration software from [www.blinkstop.co.uk](http://www.blinkstop.co.uk)  
Wire strippers, soldering iron (not Easyfit)  
Optionally: rotary switches, hook-and-loop or servo tape, heat shrink

### WARNINGS

Please check the contents and read the fitting instructions carefully before commencing

*FREEWheel solid-state channels are rated for ground-switching a maximum load of 600mA per channel, designed for use with additional relays or connected to a separate power distribution unit (not supplied).*

*FREEWheel CAN signalling has no internal switching capability and is designed to be used with a separate power distribution unit or ECU (not supplied).*

### FEATURES

- Wireless solution allows full push-button, rotary switch, paddle control and CAN signalling with a detachable steering wheel
- Choice of momentary and latching switch behaviour for all channels via USB configuration software
- Integrated body control functions – indicator cancel, headlight, IVA fog light and wiper control
- Integrated racing features – rainlight modes, flashing and Flash-to-Pass headlight mode
- Supports two simultaneous button presses – includes indicator channel hazard mode
- Uniquely, lets you use your choice of buttons, paddles and mounts. Don't be tied to a manufacturer's styling choices!
- Low-side solid-state switching up to 600mA & two variable outputs (0 - 4.7V analogue, 0 – 11 CAN)
- Top performance from a 10ms / 100Hz broadcast rate and ultimate compatibility from seven, simultaneous CAN message formats with free selection of base address, bus speed and ID length

### TRANSMITTER INSTALLATION

#### SPECIFICATION

Compact case in flame-retardant ABS plastic. Requires one 3V CR2 (27mm holder) or one CR123A (34mm holder) lithium battery. Weight with battery: 61g

Robust performance even at 2.65V. Unique Transmitter ID prevents cross-talk from nearby kits.

No need to disconnect the Transmitter battery if the vehicle is off the road. The sleep drain of under 2uA and 20mA drain per ~10msec button press allows over 20 million transmissions.

Tri-colour LED indicating performance state:

- GREEN = Transmit OK. Transmission successfully received and acknowledged by the Receiver;
- ORANGE = Transmit Fail. Transmission not acknowledged by the Receiver. Possible causes are obstruction, lack of range or de-powered Receiver (e.g., vehicle ignition is off);
- RED = Low Battery <2.65V. Replace battery now.

Transmission time of <6 milliseconds for a real-time response.



#### EASYFIT TRANSMITTER INSTALLATION INSTRUCTIONS



Easyfit Transmitter is supplied preassembled and configured to your specification.

The Easyfit Transmitter is pre-drilled to support standard 50 to 50.8mm, 70mm and 74mm PCD steering wheel bosses. The rear plate can be detached from the Transmitter and used as a guide to gently drill through the spacer disk, if required. Use a 6mm HSS drill bit with light pressure and low speed, with the parts securely clamped.

### PIGTAILED TRANSMITTER INSTALLATION INSTRUCTIONS

Use of good quality, IP67 rated OFF/[ON] momentary switches is recommended, such as Multicomp's MCPAS6B2M1CE7, available from Farnell. Illuminated switches are not supported.

#### 1. Wiring

**DO NOT solder the switches while the Transmitter battery is fitted, as damage may occur.**

The switches are all made to a common ground, so you can connect the ground wires as you wish.

Switches 1 to 8 can be assigned to Receiver outputs 1 to 8 and 11 to 16 – refer to Receiver Configuration Software.

When stripping the outer insulation, please take care not to damage the wires inside. Leave sufficient wire for future soldering of unused channels and cover with heat-shrink.

#### 2. Nut Covers (if supplied)

Fit the nut covers to the rear of the switches. It is deliberately a tight, push fit. The covers can be secured in place with a little hot melt glue or neutral cure silicone **once all testing is complete.**

#### 3. Attach the Transmitter to the Steering Wheel

The Transmitter can be easily attached to the reverse of the wheel or button plate using hook-and-loop pads or servo tape.

Wire Colour	Function
BLACK	Ground
ORANGE	3V Potentiometer Live Ref
RED	Switch 1
GREEN	Switch 2
BLUE	Switch 3
BROWN	Switch 4
GREY	Switch 5
PINK	Switch 6
CYAN	Switch 7
PURPLE	Switch 8
YELLOW	Ch9 Pot1 Signal
WHITE	Ch10 Pot2 Signal

**Transmitter wiring key**

### TRANSMITTER BATTERY & TESTING INSTRUCTIONS

#### 1. Battery Fitting and Removal

Fit the supplied battery to the transmitter battery housing, noting that the '+' end of the battery is nearest to the LED. As the battery is deliberately tightly fitted in the holder, exercise care when removing.

#### 2. IMPORTANT - Transmitter Testing

Follow the Receiver Configuration Software instructions to connect the Receiver to your Windows PC or laptop and to verify that your button presses for each channel are being sent by the Transmitter.

#### 3. Battery Voltage

With the Receiver connected to your Windows PC or laptop and communication with the Transmitter established, approximate battery strength can be checked using the Receiver Configuration Software.

A more precise voltage can be obtained from the CAN signal in message TXmV, within the All\_Compact\_U8 frame in Byte 6 (scaling x10, offset 1000mV). The default is 3000mV until active communication starts. A suitable alarm value is 2700mV.

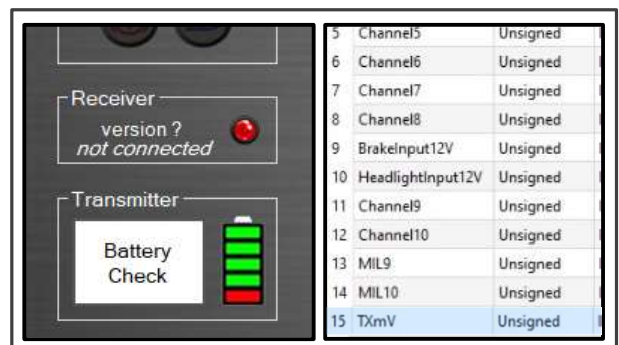

## RECEIVER CONFIGURATION SOFTWARE

### SOFTWARE INSTALLATION AND USAGE INSTRUCTIONS

NOTE: DO NOT disconnect the USB power during programming or the chip memory may corrupt!

#### 1. Software Installation

Connect the Receiver USB cable to the Windows PC. Windows 10 and 11 are supported. Windows will auto-detect and install the FTDI Driver.

In the event the PC does not self-install the FTDI driver, download and install FTDI's VCP Virtual COM Port driver from: <http://www.ftdichip.com/Drivers/VCP.htm>

#### 2. Identify the correct COM port used by FREEWheel

Open Windows Device Manager [Search .. and enter 'Device Manager']. The port will disappear and reappear as you remove and insert the Receiver USB lead.

Download, extract to Desktop and run the FREEWheel16.exe program from the Downloads page at: <https://www.blinkstop.co.uk/shop/downloads>

#### 3. Using the Software

Choose the correct COM port from the available drop list and click 'Connect'. The existing channel configuration and virtual relay states will be displayed (physical relays are not powered by USB).

Pressing steering wheel buttons connected to the Transmitter will illuminate the corresponding buttons and toggle or flash the virtual relay states on the software.



### INPUT SOURCE SELECTION

#### 4. Select the Input Configuration tab to activate CAN integrations and map the channels

Enable CAN switchboard and/or CAN keypad using the associated tick boxes. Enabling a keypad spawns an Options button which offers a choice of keypad sizes, light intensities and colours.

Assign channels to individual switchboard inputs, keypad keys, FREEWheel switches and CAN output from our Mil-spec rotary switches. Note that changes are immediately committed to the Receiver.

### RECEIVER CHANNEL OUTPUT BEHAVIOUR CONFIGURATION

#### 5. Use the Input Configuration tab to set the channel behaviours

If using a PDM or similar to control your circuits, you may wish to set all channels to momentary behaviour. Alternatively, select the desired smart functions using the dropdown boxes. All channels allow a choice of momentary or latching behaviour, and those with coloured icons include a special function such as indicator cancelling and wiper mode. **CAUTION: use Momentary behaviour for channels activated by our Mil-spec rotary switches.** Note that changes are immediately committed to the Receiver.

Continue to CAN Configuration if required otherwise press 'Disconnect' and 'Close' to disconnect the Receiver from the USB software, then remove the USB cable and proceed to Receiver Installation.

### CAN CONFIGURATION

#### 6. Select the CAN Addressing tab and configure the Receiver CAN communication

Message ID: This is the Base Address in hexadecimal. The default is 0x500 (1280 decimal) with 11-bit (standard) Identifier. Follow the instructions on the CAN Addressing tab to set the Receiver communication to match your intended CAN-connected node (ECU / PDU / dash etc).

Once done, click 'Program'. When successful, you will see 'Success' displayed.

To achieve two-way communication, you will also need to configure your existing CAN node. If your node accepts industry standard .dbc CAN database files, you can use file KCE\_WirelessCAN.dbc from the Downloads page at <https://www.blinkstop.co.uk/shop/downloads>, otherwise configure your node with the data below.

For best performance, the FREEWheel Receiver uses a 10ms (100Hz) broadcast rate.

For best compatibility, the FREEWheel Receiver outputs its CAN message in seven simultaneous standard formats [see CAN messages table and individual message illustrations, following]. Pick the most suitable format and set your existing CAN node accordingly.

**Note:** Kvaser Database Editor 3 is recommended for viewing CAN .dbc files and is freely available from <https://www.kvaser.com/download/>

To disconnect the Receiver from the USB software, press 'Disconnect' then 'Close'. Now you can safely disconnect the USB cable.

Proceed to Receiver Installation.

### CAN MESSAGES

Message	Contents	Format	Address / default
All_Compact_U8	All signals	8-bit Unsigned compact industry standard (e.g. AiM)	Base Address 0x500 hex / 1280 dec
Ch1_4_U16LE	channels 1 - 4	16-bit Unsigned Little Endian / LSB First (e.g. EMtron)	Base Address +11 0x50B hex / 1291 dec
Ch5_8_U16LE	channels 5 - 8	16-bit Unsigned Little Endian / LSB First (e.g. EMtron)	Base Address +12 0x50C hex / 1292 dec
Ch9_10_U16LE	channels 9 - 10	16-bit Unsigned Little Endian / LSB First (e.g. EMtron)	Base Address +13 0x50D hex / 1293 dec
Ch1_4_S16BE	channels 1 - 4	16-bit Signed Big Endian / MSB First (e.g. Syvecs)	Base Address +1 0x501 hex / 1281 dec
Ch5_8_S16BE	channels 5 - 8	16-bit Signed Big Endian / MSB First (e.g. Syvecs)	Base Address +2 0x502 hex / 1282 dec
Ch9_10_S16BE	channels 9 - 10	16-bit Signed Big Endian / MSB First (e.g. Syvecs)	Base Address +3 0x503 hex / 1283 dec

**CAN messages**

Messages

Messages & Signals ▼ All Signals ▼ Nodes List ▼ Communication Matrix

Name	ID	Decimal	Frame Format	DIC	TX Mode	Comment
Compact_U8	1200	Standard	8	WirelessPac...	10ms U8 [Base Address from config tool]	
_L4_U16LE	1201	Standard	8	WirelessPac...	10ms Unsigned 16 bit Little Endian [Base=11]	
_L8_U16LE	1202	Standard	8	WirelessPac...	10ms Unsigned 16 bit Little Endian [Base=12]	
_L10_U16LE	1203	Standard	8	WirelessPac...	10ms Unsigned 16 bit Little Endian [Base=13]	
_L4_S16BE	1204	Standard	8	WirelessPac...	10ms Signed 16 bit Big Endian [Base=1]	
_L8_S16BE	1205	Standard	8	WirelessPac...	10ms Signed 16 bit Big Endian [Base=2]	
_L10_S16BE	1206	Standard	8	WirelessPac...	10ms Signed 16 bit Big Endian [Base=3]	

Messages

Messages & Signals ▼ All Signals ▼ Nodes List ▼ Communication Matrix

Name	Type	Byteorder	Mode	Bitspos	Length	Factor	Offset	Minimum	Maximum	Unit	Comment	Values
Apout1	Unsigned	Intel	Signal	7	1	1	0	0	0	1 Bin	0 Open Circuit	Open Circuits=0, Closed Circuits=1
Apout2	Unsigned	Intel	Signal	6	1	1	0	0	0	1 Bin	0 Open Circuit	Open Circuits=0, Closed Circuits=1
Apout3	Unsigned	Intel	Signal	5	1	1	0	0	0	1 Bin	0 Open Circuit	Open Circuits=0, Closed Circuits=1
Apout4	Unsigned	Intel	Signal	4	1	1	0	0	0	1 Bin	0 Open Circuit	Open Circuits=0, Closed Circuits=1
Apout5	Unsigned	Intel	Signal	3	1	1	0	0	0	1 Bin	0 Open Circuit	Open Circuits=0, Closed Circuits=1
Apout6	Unsigned	Intel	Signal	2	1	1	0	0	0	1 Bin	0 Open Circuit	Open Circuits=0, Closed Circuits=1
Apout7	Unsigned	Intel	Signal	1	1	1	0	0	0	1 Bin	0 Open Circuit	Open Circuits=0, Closed Circuits=1
Apout8	Unsigned	Intel	Signal	0	1	1	0	0	0	1 Bin	0 Open Circuit	Open Circuits=0, Closed Circuits=1
analogout12V	Unsigned	Intel	Signal	23	1	1	0	0	0	1 Bin	1 Input High	Low=0, High=1
analoginput12V	Unsigned	Intel	Signal	22	1	1	0	0	0	1 Bin	1 Input High	Low=0, High=1
Apout9	Unsigned	Intel	Signal	32	8	1	0	0	0	255 Dec	Analogue	Low=0, High=255
IL9	Unsigned	Intel	Signal	24	8	1	0	0	0	255 Dec	Analogue	Low=0, High=255
IL10	Unsigned	Intel	Signal	56	8	1	0	0	0	11 Dec	Analogue MIL switch	
mV	Unsigned	Intel	Signal	48	8	10	1000	1000	3500	Dec	Analogue MIL switch	
Apout11	Unsigned	Intel	Signal	21	1	1	0	0	0	1 Bin	Transmitter battery voltage	Open Circuits=0, Closed Circuits=1
Apout12	Unsigned	Intel	Signal	20	1	1	0	0	0	1 Bin	0 Open Circuit	Open Circuits=0, Closed Circuits=1
Apout13	Unsigned	Intel	Signal	19	1	1	0	0	0	1 Bin	0 Open Circuit	Open Circuits=0, Closed Circuits=1
Apout14	Unsigned	Intel	Signal	18	1	1	0	0	0	1 Bin	0 Open Circuit	Open Circuits=0, Closed Circuits=1
Apout15	Unsigned	Intel	Signal	17	1	1	0	0	0	1 Bin	0 Open Circuit	Open Circuits=0, Closed Circuits=1
Apout16	Unsigned	Intel	Signal	16	1	1	0	0	0	1 Bin	0 Open Circuit	Open Circuits=0, Closed Circuits=1

All\_Compact\_U8

## ENHANCED SOLID-STATE RECEIVER INSTALLATION

### SPECIFICATION

#### 16-CHANNEL RECEIVER:

- Weight with/without 0.7m loom: 285g/120g.
- Wiring loom uses 23-pin sealed, genuine TE connector and 18AWG heat resistant, high temperature, thin wall wires with tinned copper.

#### SOLID-STATE CHANNELS (DIGITAL 1 – 8 and 11 - 16):

Independent, low-side drive channels of 0.6A capability, with in-built short circuit / overcurrent protection, open circuit detection and flyback voltage clamping for inductive loads. These channels can ground switch typical automotive relay coil circuits directly, or low current loads with no further isolation required.



**16-Channel Receiver**

Digital channels are open circuit by default at ignition ON and are switched by the Transmitter. Digital channels are configured using the FREEWheel USB software and have behaviour options of:

- ALL: momentary Normally Open (ON) (Transmitter button follower)
- ALL: latching ON / OFF with each separate Transmitter button press
- ALL: inverted momentary Normally Closed (NC) (Transmitter button follower)
- ALL: 1Hz flashing and 2Hz flashing ON / OFF
- Channels 1 & 2: indicator control
- Channel 3: high and low beam function with Flash-to-Pass feature
- Channel 4: IVA fog function
- Channels 5 & 16: single button hazard function (triggers channels 1 and 2 simultaneously)
- Channel 6: intermittent wiper function
- Channel 8: rainlight function

#### ROTARY CHANNELS (ANALOGUE 9 - 10):

The Receiver outputs a variable 0 – 4.7V CAN 0 – 255 value proportional to the position of a connected potentiometer, or a discrete 0 – 11 signal MIL9 and MIL10 for the Kit Car Electronics' Mil-spec rotary switch.

Analogue channels can be inverted to give a 4.7 – 0V output using the FREEWheel USB software.

Details of all individual features can be found towards the end of this booklet.

### INSTALLATION INSTRUCTIONS

The FREEWheel Receiver contains the solid-state grounding switch circuits. Each circuit can sink up to 600mA and has an internal, self-resetting fuse.

Externally, there is a white wire for each channel which is to be connected to the ground side of any load. The Receiver controls the load by connecting the white wire directly to 'ground'.

Circuits below 600mA can be switched directly (e.g., certain LED lighting circuits).

#### 1. Wiring

Identify an ignition-switched circuit that can be used for the power supply to FREEWheel. The FREEWheel Receiver draws little current (<500mA), so will not increase the circuit load significantly.

Identify a suitable Ground connection, ideally direct to the vehicle chassis.

Identify the existing circuits and schematics. These will be critical to successful installation.

See Figure 2 for suggested indicator and main beam wiring diagrams. Some vehicles as standard do not provide high beam flashing unless headlamps are ON (e.g., Westfields), so use the elements of the diagrams applicable to your vehicle. Choose a cool location for the Receiver inside the car, with minimal (metal) obstructions between Receiver and Transmitter. Behind the dashboard is normally an ideal place.

**With the vehicle battery disconnected**, connect Receiver Power and Ground to the previously identified wires.

#### 2. Receiver Testing

Re-connect the vehicle battery.

Check that the Transmitter light is reliably GREEN on button presses. ORANGE means that there is a probable obstruction to two-way communication. You can test the range of the system using this light for indication.

Once you have reliable communication between Transmitter and Receiver, connect the Windows PC to the USB connector and use the FREEWheel software to configure the channels, if you have not already done so (see Receiver Configuration Software). The software will show the live state of the switching and button presses and the Transmitter battery voltage status.

Now **disconnect the vehicle battery** and complete the installation of the desired integrated functions.

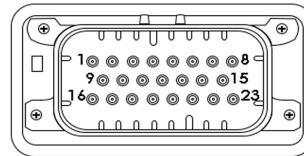
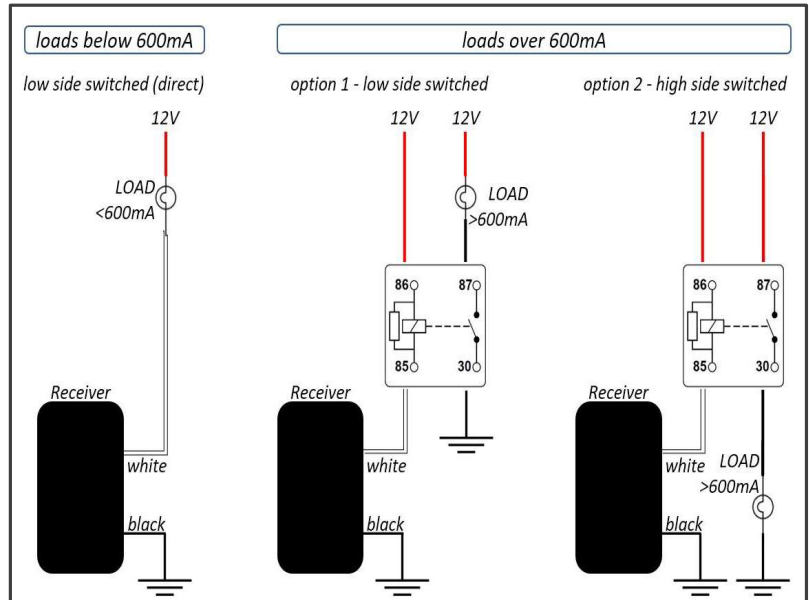

**23-PIN AMPSEAL CONNECTOR PIN-OUT DIAGRAM**

PIN	COLOUR	FUNCTION / CHANNEL
1	WHITE	CH1 GROUND SWITCH
2	WHITE	CH2 GROUND SWITCH
3	WHITE	CH3 GROUND SWITCH
4	WHITE	CH4 GROUND SWITCH
5	WHITE	CH5 GROUND SWITCH
6	WHITE	CH6 GROUND SWITCH
7	WHITE	CH7 GROUND SWITCH
8	WHITE	CH8 GROUND SWITCH
9	-	-
10	RED	12V IGNITION POWER
11	BLACK	VEHICLE GROUND
12	GREEN	12V SENSE
13	BLUE	12V SENSE
14	WHITE	CH9 ANALOGUE OUT 0-5V
15	WHITE	CH10 ANALOGUE OUT 0-5V
16	-	CH16 GROUND SWITCH
17	-	CH15 GROUND SWITCH
18	-	CH14 GROUND SWITCH
19	-	CH13 GROUND SWITCH
20	-	CH12 GROUND SWITCH
21	-	CH11 GROUND SWITCH
22	WHITE	CAN LOW
23	WHITE	CAN HIGH

**Enhanced Solid-State 16 Receiver 23-pin connector wiring key**

### INTEGRATED BlinkSTOP FUNCTION

CHANNELS 1 AND 2 SET TO [INDICATORS]



#### INSTRUCTIONS FOR OPERATION

An indicator can be toggled ON and OFF with each press of a button. Flash rate can be controlled by FREEWheel to 60, 75, 90, 105 or 120 flashes per minute or by your flasher relay (user-configurable).

Toggling to ON begins a cancel timer. Indicating will auto-cancel once the timer has elapsed (6 to 30 seconds, user-configurable). Indicator auto-cancelling is inhibited while the brakes are pressed, and afterwards for a short time so that the indicators can remain ON in traffic or while waiting to turn.

To change indicator, push the opposite button once. The current indicator will cancel, and the opposite indicator will toggle to ON and begin flashing. The cancelling timer will reset.

To use the Hazard function, push both buttons together at the same time. To cancel, press either button. For a suggested wiring plan, see Figure 1 on the following page.

### INTEGRATED BeamSTOP HEADLIGHT FUNCTION

CHANNEL 3 SET TO [MAIN]



#### INSTRUCTIONS FOR OPERATION

BeamSTOP allows full control of headlight main (high) beam and dipped (low) beam.

If the headlights are OFF, the main beam will light for the duration of the button press. If the headlights are ON, BeamSTOP allows each button press to alternate between latched-dipped and latched-main beam.

If Flash-to-Pass is enabled, a half-second press will trigger 4 seconds of rapid flashing of the main beam.

For a suggested wiring plan, see Figure 2 on the following page.

### INTEGRATED FOG LIGHT 'IVA' FUNCTION

CHANNEL 4 SET TO [FOG]



#### INSTRUCTIONS FOR OPERATION

Channel 4 can be used as an auto-cancelling fog light channel. When suitably connected and the headlights are OFF, the fog light will automatically cancel and is inhibited from operation by button press.

WIRING: Connect the blue/brown wire to the headlight switch, as shown Figure 2.

FIGURE 1 // ENHANCED SOLID-STATE 16-CHANNEL SYSTEMS – SUGGESTED INDICATOR WIRING PLAN

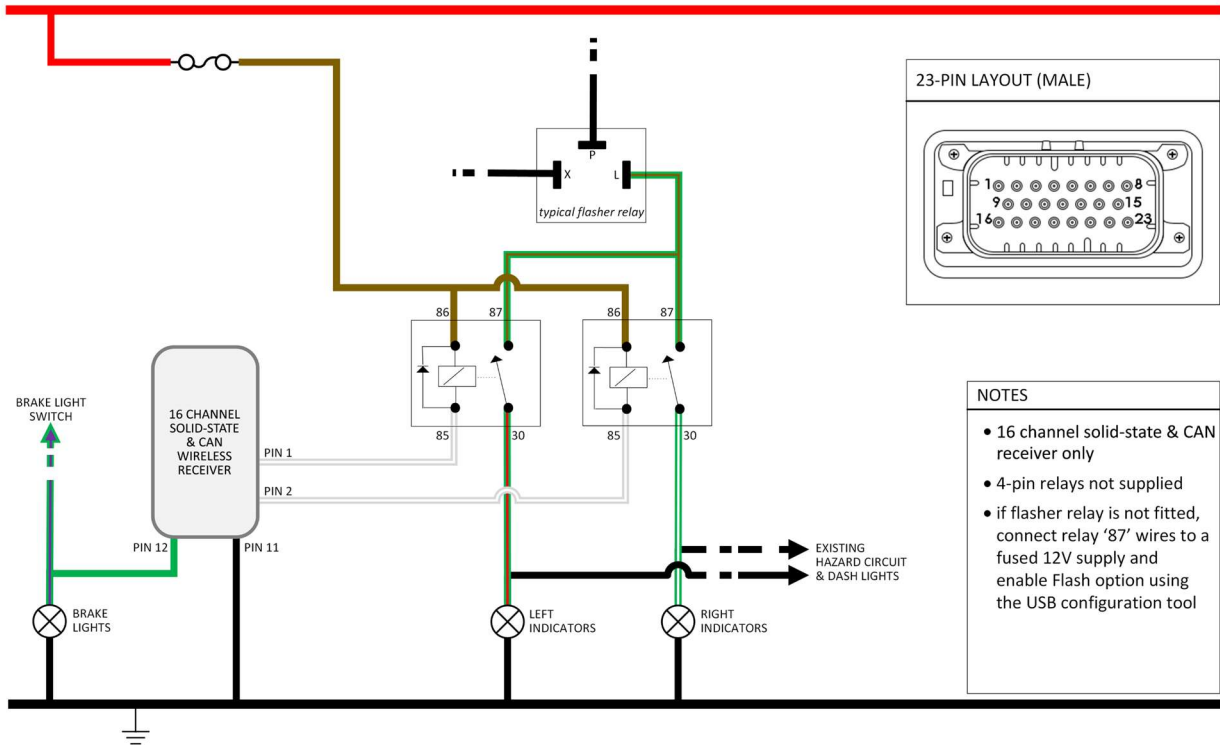
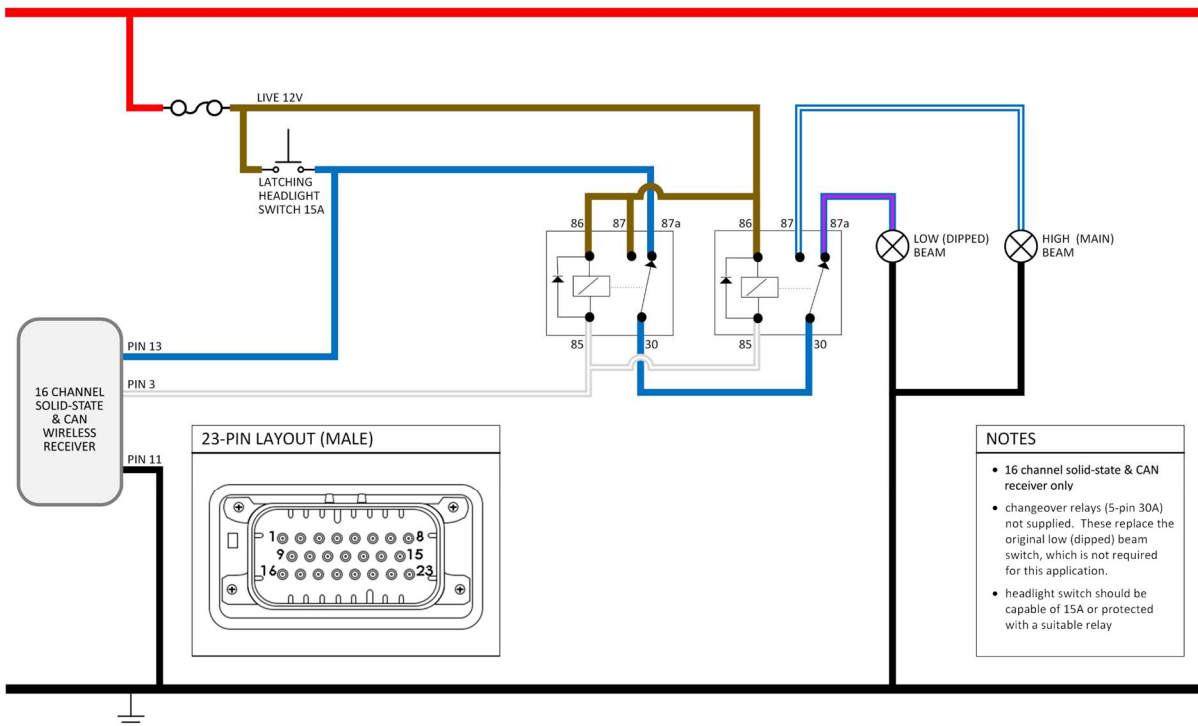

FIGURE 2 // ENHANCED SOLID-STATE 16-CHANNEL SYSTEMS – SUGGESTED MAIN BEAM WIRING PLAN



## HAZARD FUNCTION

CHANNELS 5 or 16 SET TO [HAZARD]



### INSTRUCTIONS FOR OPERATION

Channel 5 or 16 can be used as a single button hazard channel and require channels 1 and 2 to be set to the BlinkSTOP indicator function. A single button press will cause the indicator outputs to be live; flash rate can be controlled by FREEWheel to 60, 75, 90, 105 or 120 flashes per minute, or by your flasher relay.

NOTE: some markets require that hazard lights can be operated by a single lit button when the ignition is off, therefore this feature should be used with suitable consideration.

## WIPER FUNCTION

CHANNEL 6 SET TO [WIPER]



### INSTRUCTIONS FOR OPERATION

A short press will toggle between [OFF] and latched [ON]. A one-second press will trigger an intermittent [ON]/[OFF] with the durations configurable to 250ms, 500ms, 1s, 2s, 4s, 7s and 10s. A subsequent one-second press will cancel the intermittent mode and return to the previous state.

WIRING: Connect the Receiver channel wire to the wiper's low speed and park circuit.

## INVERTED MOMENTARY FUNCTION

CHANNEL SET TO MOMENTARY [INVERTED]



### INSTRUCTIONS FOR OPERATION

Any digital channel can be an inverted momentary channel, i.e., normally closed. The channel will be open at power up with normally closed behaviour starting once power-on checks are completed (<50ms).

## FLASH FUNCTION

CHANNEL SET TO [FLASH 1Hz or 2Hz]



### INSTRUCTIONS FOR OPERATION

A short press will trigger a flashing mode. A subsequent press cancels and returns to the previous state.

### INTEGRATED RAINLIGHT RACE FUNCTION



CHANNEL 8 SET TO [RAINLIGHT]

#### INSTRUCTIONS FOR OPERATION

Channel 8 can be used as a racing mode rainlight. A short press of the steering wheel button will latch the rainlight ON and a longer, one-second press will trigger the 'Rain Hazard' 4Hz flashing mode. A subsequent one-second press will cancel the Rain Hazard mode and return to the previous state.

**WIRING:** Connect the Receiver channel wire to the rainlight's power circuit.

### POTENTIOMETER CHANNELS



CHANNELS 9 AND 10

#### INSTRUCTIONS FOR OPERATION

The Transmitter supports 2Hz sampling of two independent 10kΩ potentiometers.

Initial voltage output is 0V at power-up, until two-way communication is established. Ensure that this is considered in the final intended switching design.

With ignition ON, pressing any of the channels 1 to 8 or 11 to 16 momentary switches initiates communication, and the green Transmitter LED will flash at 2Hz to show successful two-way messaging. The momentary channels will each trigger a transmission immediately on button press, independently of the 2Hz potentiometer transmission frequency.

The Transmitter LED will automatically power down when the vehicle ignition is powered OFF.

**WIRING:** Fit a 10kΩ potentiometer or a Kit Car Electronics' Mil-spec rotary switch to each Transmitter potentiometer channel as illustrated.

The Receiver unit will output an analogue (0 to 4.7V) voltage proportional to the position of the potentiometer.

Connect each analogue output to a high impedance input sampling circuit (typically > 50kΩ impedance) to ensure the voltage is not reduced.



3V – orange (REF)  
channel 9 or 10 – yellow or white (SIG)  
ground – black (GND)



**GUARANTEE**

All our products come with a two-year guarantee, except our batteries which have a five-year guarantee.

**RETURNS & EXCHANGES**

You can return many of our products within 14 days from delivery, however customised goods and bespoke hardware, firmware and software cannot be returned or exchanged.

**GOT A PROBLEM OR CHANGED YOUR MIND?**

In all cases, we will be reasonable and responsive and will endeavour to give an excellent service. Please see [blinkstop.co.uk/shop](http://blinkstop.co.uk/shop) for further details.

# **BlinkSTOP.co.uk**

---

Contact:  
[info@blinkstop.co.uk](mailto:info@blinkstop.co.uk)

**Another quality product from**

*Kit Car Electronics Limited*

